

# XTOOL | M1 Ultra

快速入門指南



**物品清單** ----- **01**

**認識 xTool M1 Ultra** ----- **02**

**使用前準備** ----- **04**

**使用 xTool M1 Ultra** ----- **08**

**指示燈說明** ----- **16**

## 物品清單

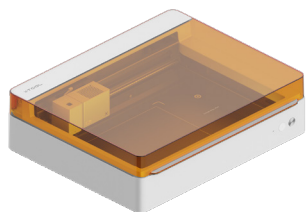

01 xTool M1 Ultra



02 雷射模組

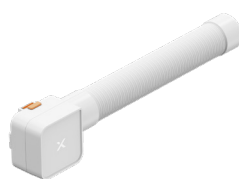

03 排煙模組



04 USB 連接線



05 電源適配器&電源線



06 細切刀



07 針管筆



08 筆套

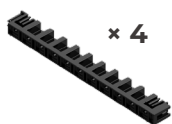

09 三稜條支架



10 三稜條

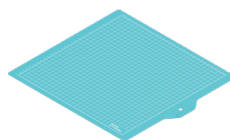

11 低黏度切割墊

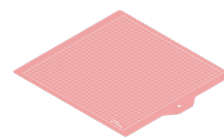

12 紡織品切割墊



13 濾棉



14 鑰匙



15 潤滑脂

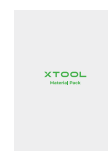

16 材料包



17 鏡片座 (備件)



18 鏡片座旋轉片



19 螺絲起子



20 多功能托架



21 裁切刀



22 底板手轉螺絲 (備用零件)



23 快速入門指南



24 安全說明

# 認識 xTool M1 Ultra

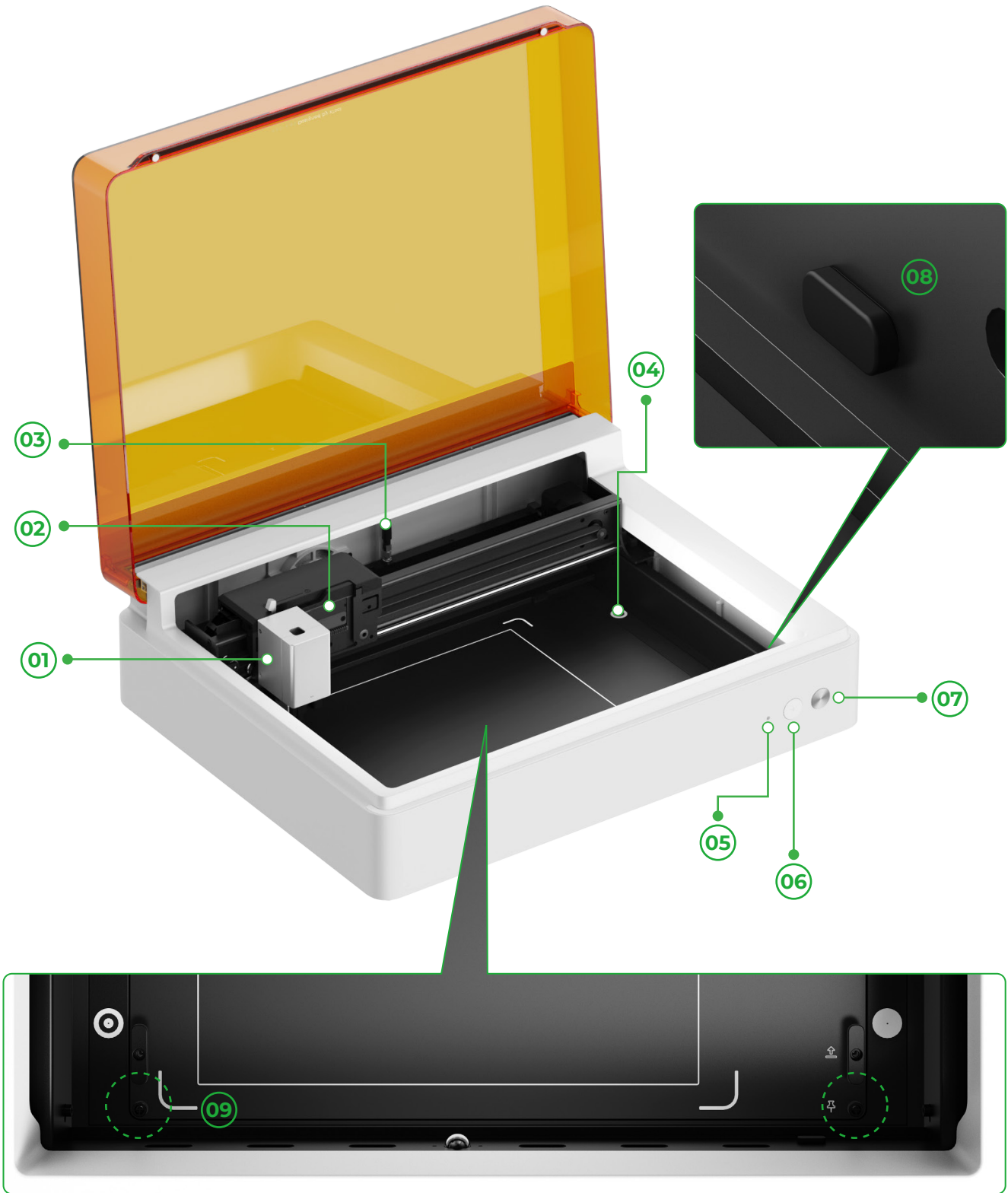



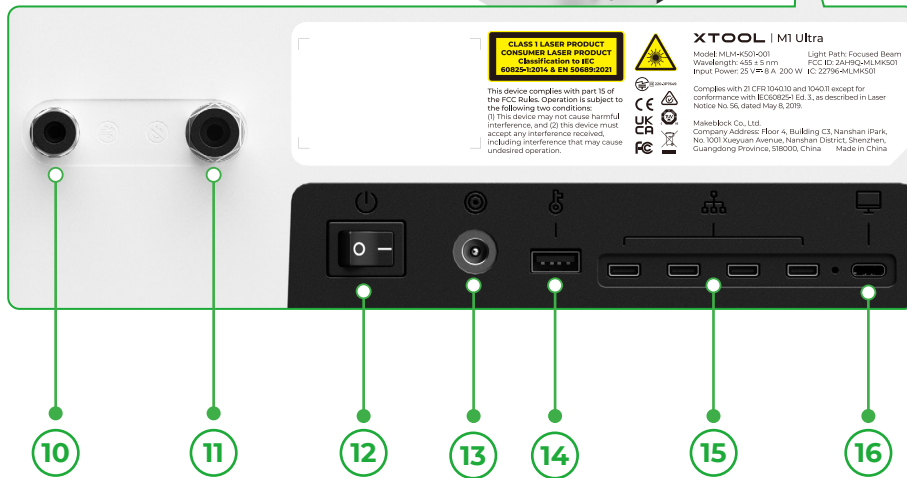
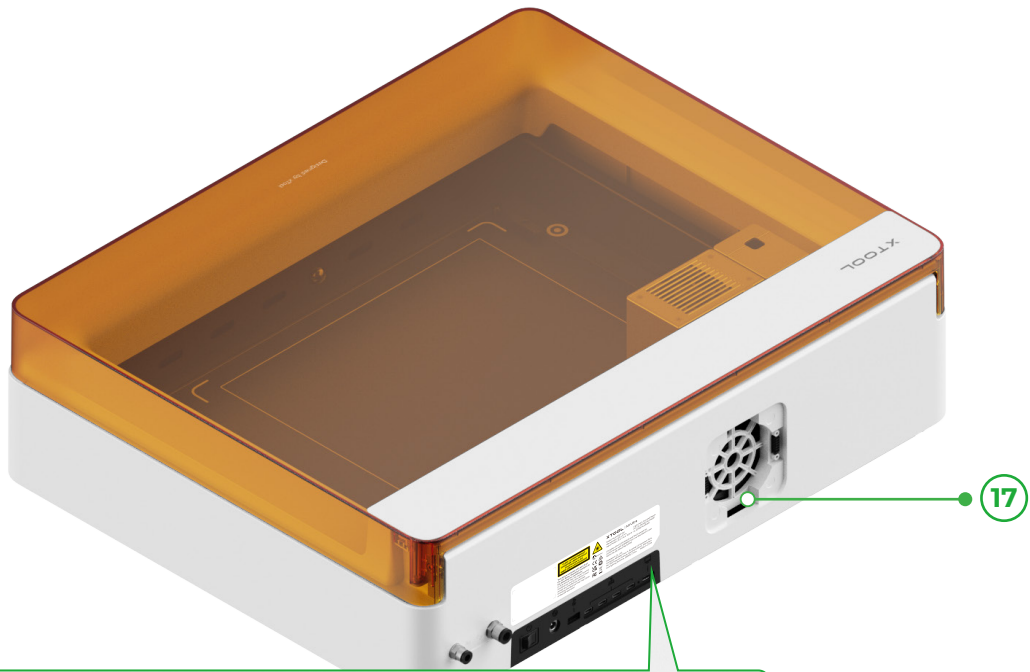

01 基本托架

02 多功能支架

03 Wi-Fi 天線

04 拍照定位點

05 指示燈

06 標點按鈕

07 開始 / 停止按鈕

08 旋轉附件連接埠

09 底板手轉螺絲

10 空氣輔助裝置氣管接頭

11 火焰安全裝置氣管接頭

12 電源開關

13 電源接口

14 鑰匙插口

15 擴展連接埠 × 4

16 USB 連接口

17 排煙口

## 使用前準備

### 1 拆下固定在 x 軸和 y 軸導軌上的螺絲

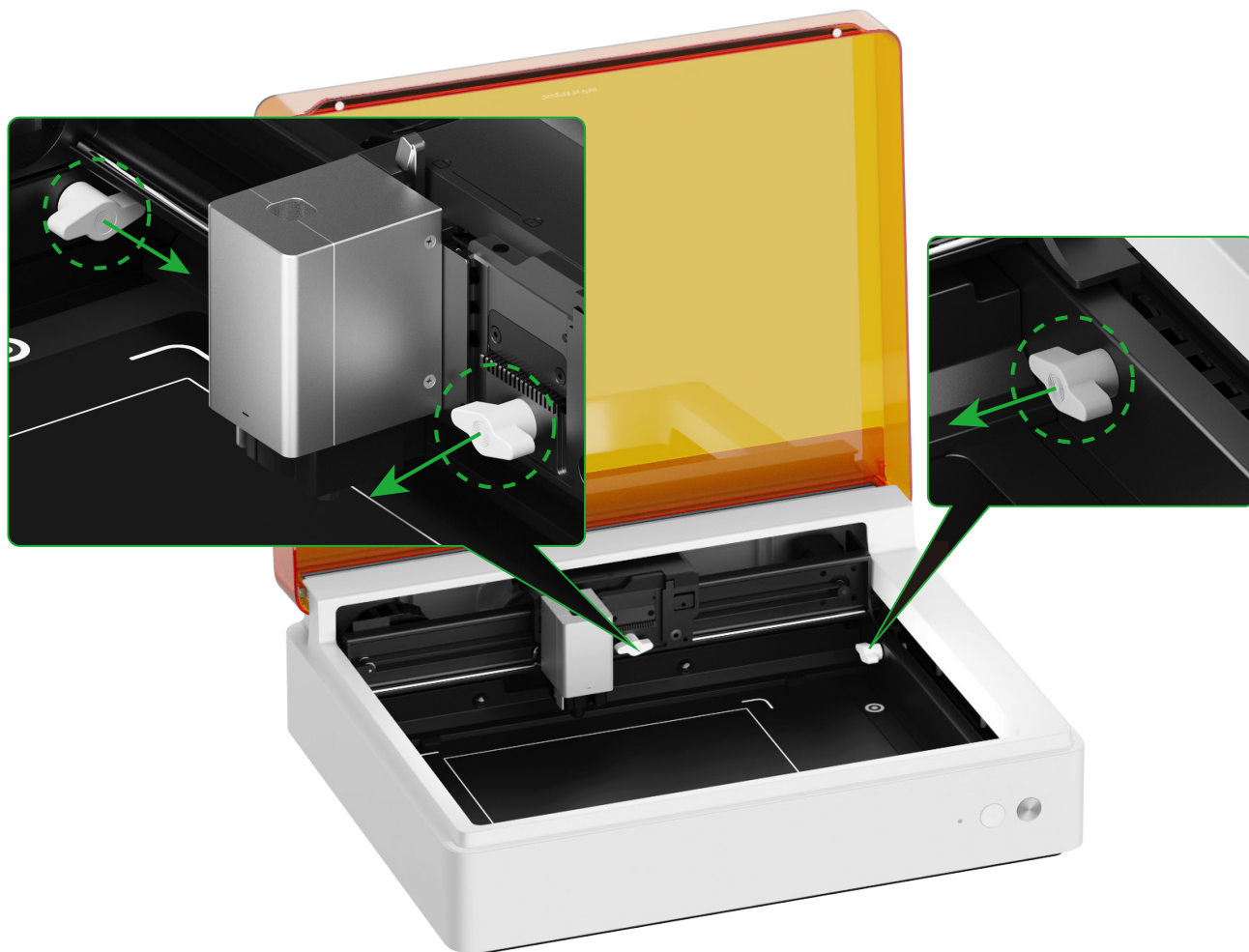

### 2 安裝雷射模組

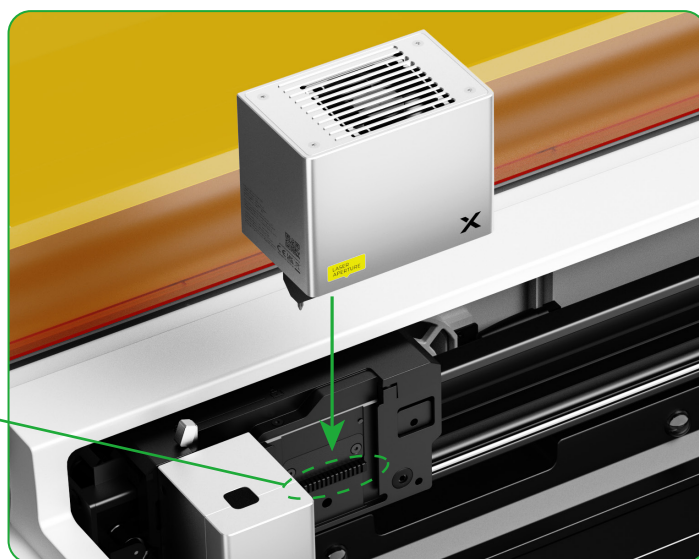

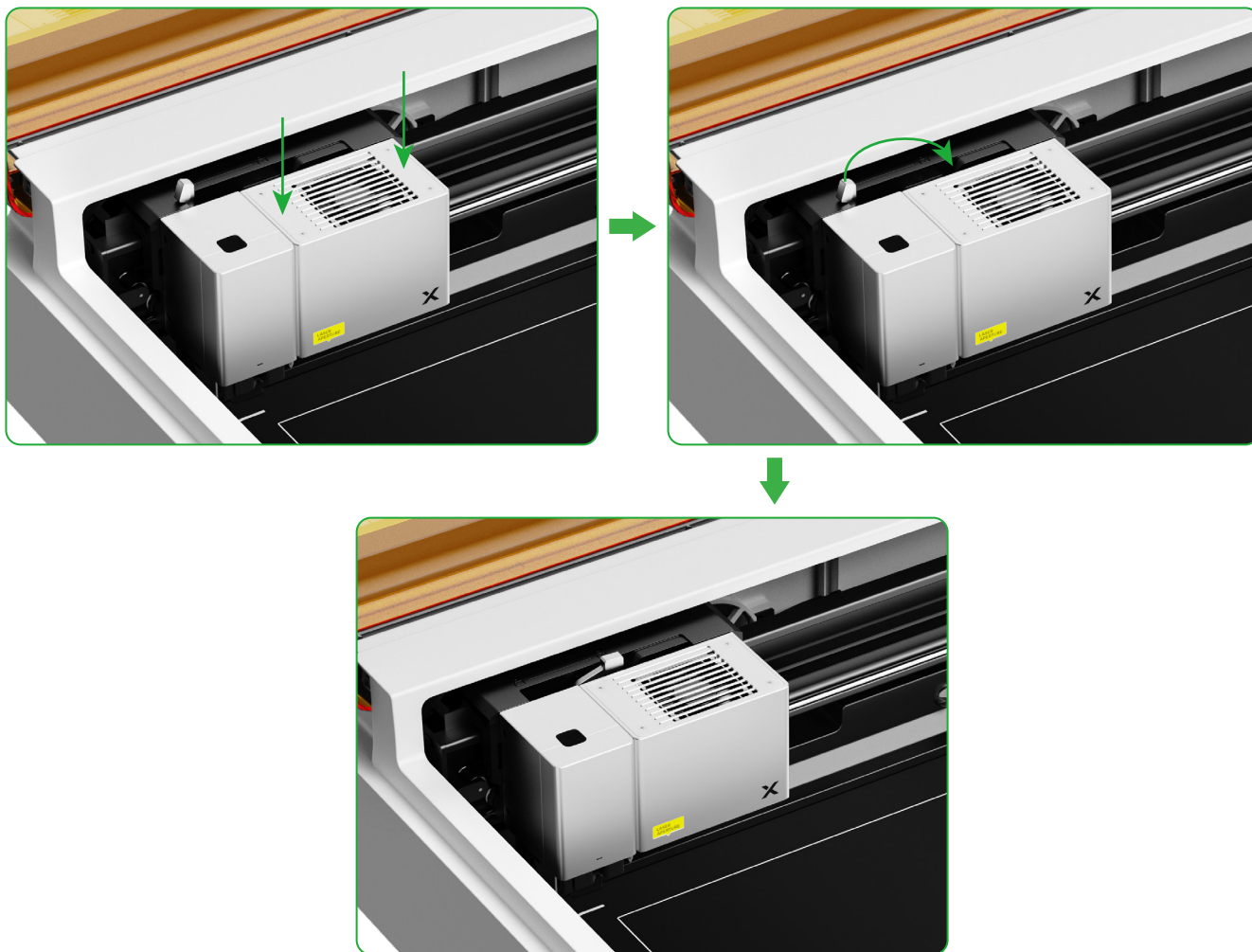

### 3 安裝排煙模組

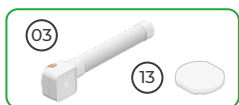

使用排煙模組前請先安裝濾棉。排煙模組若未安裝濾棉，使用時容易吸附煙塵造成損壞。

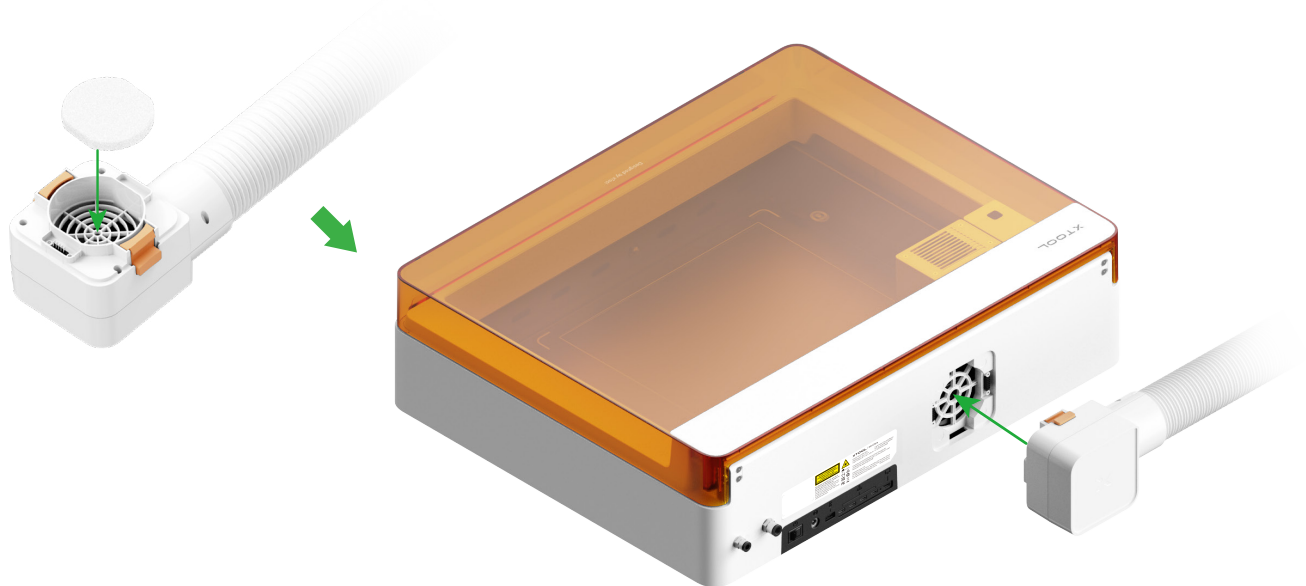

#### 4 將鑰匙正確插入

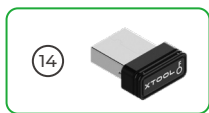

- 插入鑰匙即可解鎖機器的加工及其相關功能。
- 拔出即可鎖定加工及其相關功能。

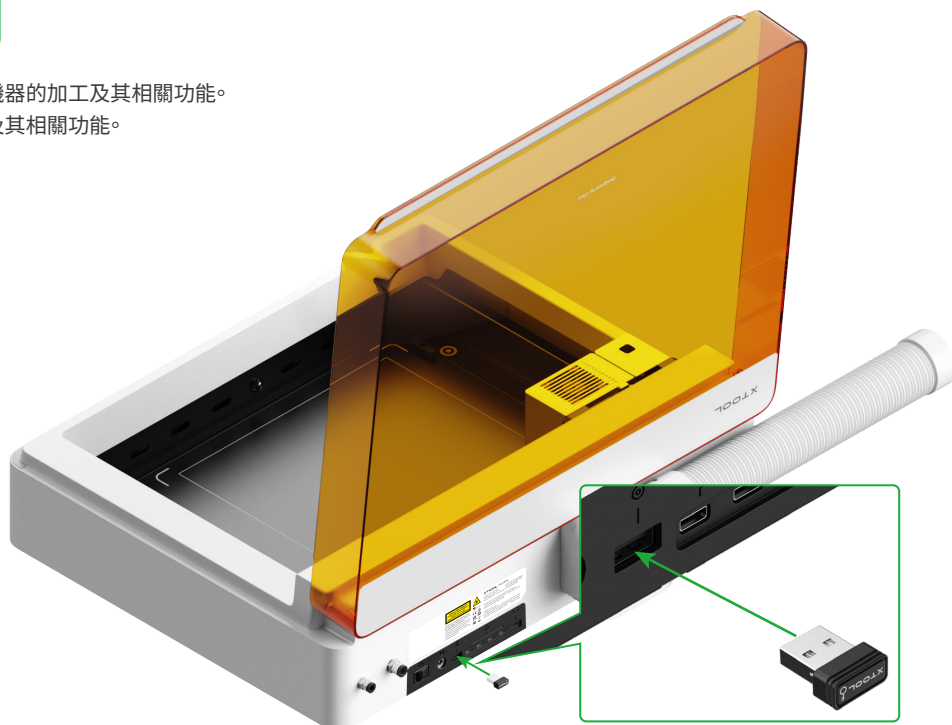

#### 5 連接電源。

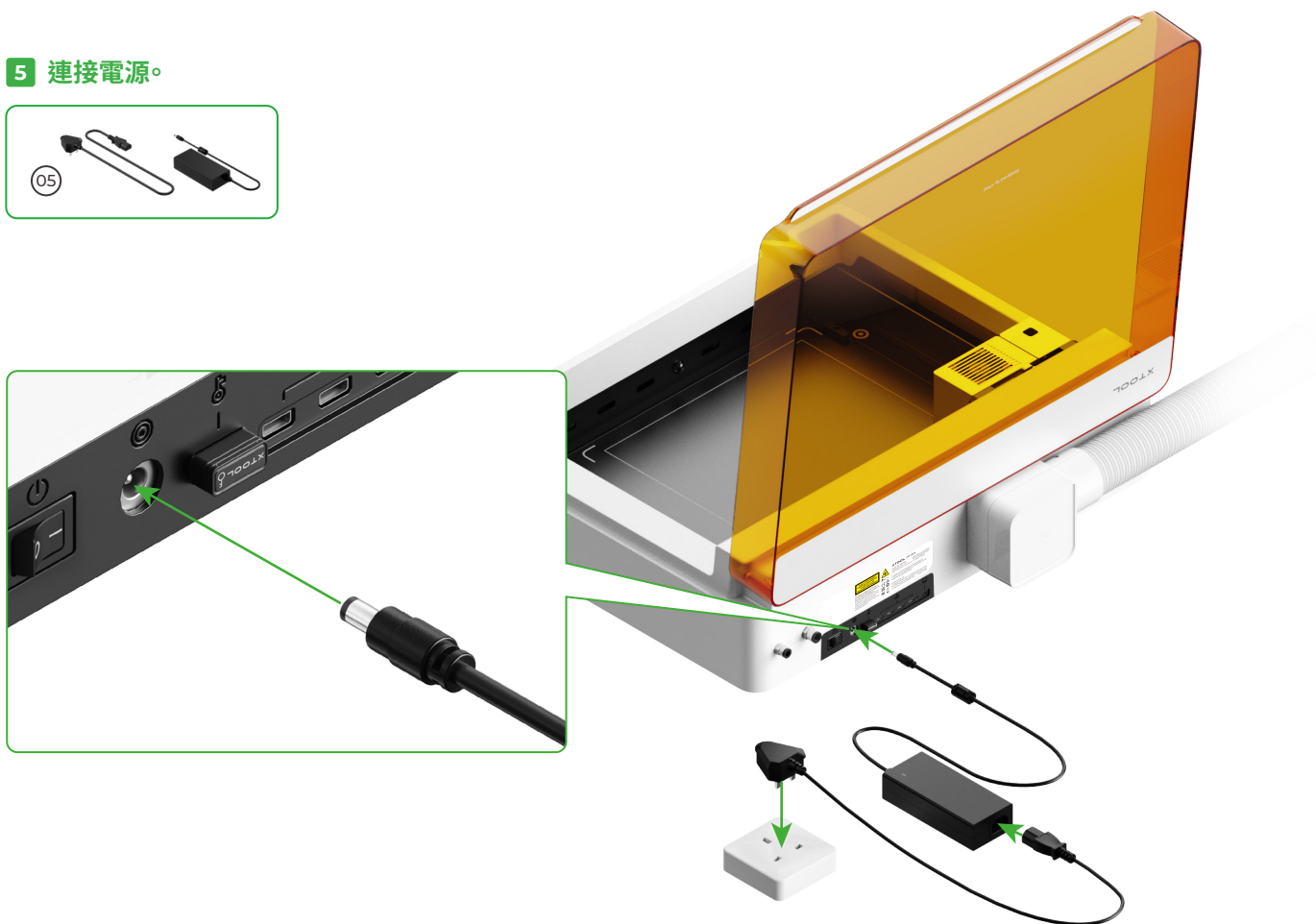
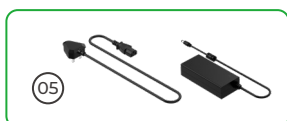

## 6 下載並安裝 XCS 軟體



前往 [xtool.com/software](https://xtool.com/software) 下載並安裝 xTool 官方軟體 XCS (xTool Creative Space)。

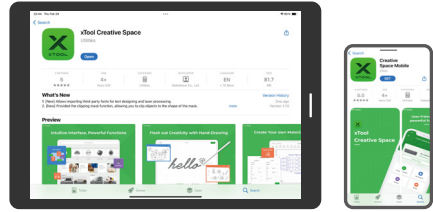

在應用商店搜尋 **xTool Creative Space**，或掃描以下二維碼下載應用程式。



## 7 連接 xTool M1 Ultra 至電腦

- 打開 xTool M1 Ultra 的電源開關，連接設備，然後在 XCS 軟體中連接 xTool M1 Ultra。

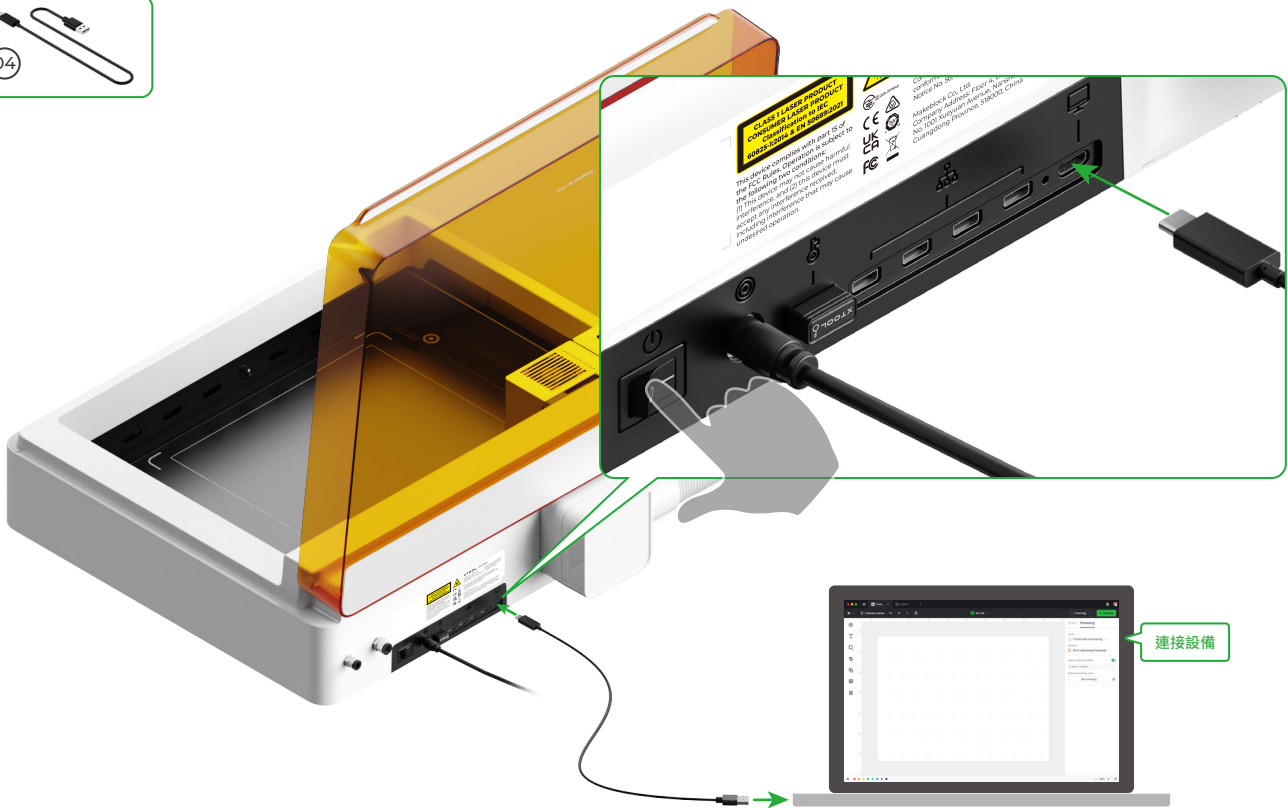
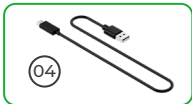

- 如需了解更多如何使用 xTool M1 Ultra 操作 XCS 軟體進行加工，掃描以下二維碼或前往 [support.xtool.com/product/35](https://support.xtool.com/product/35)。





## 使用 xTool M1 Ultra

### 使用雷射器進行切割加工時

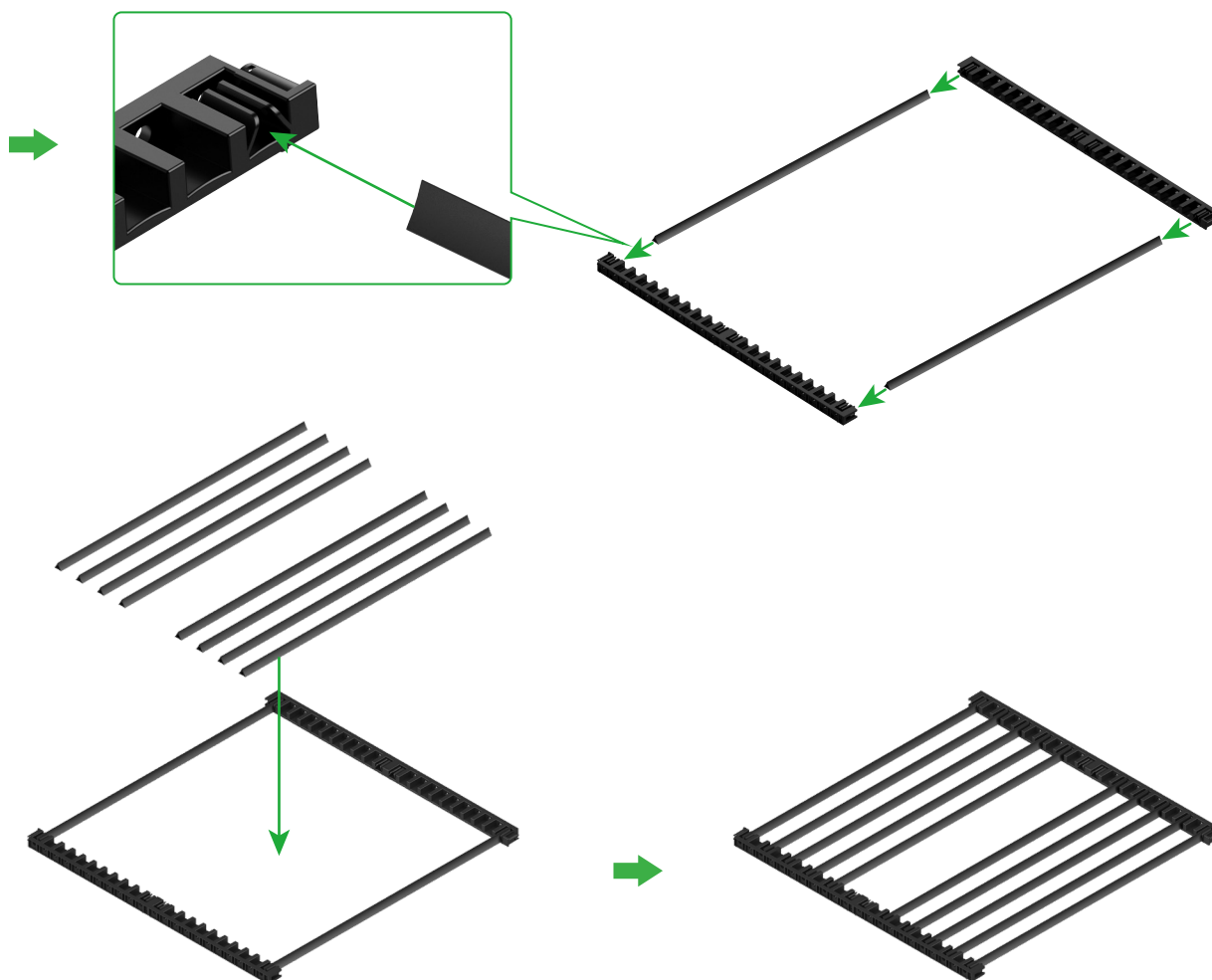
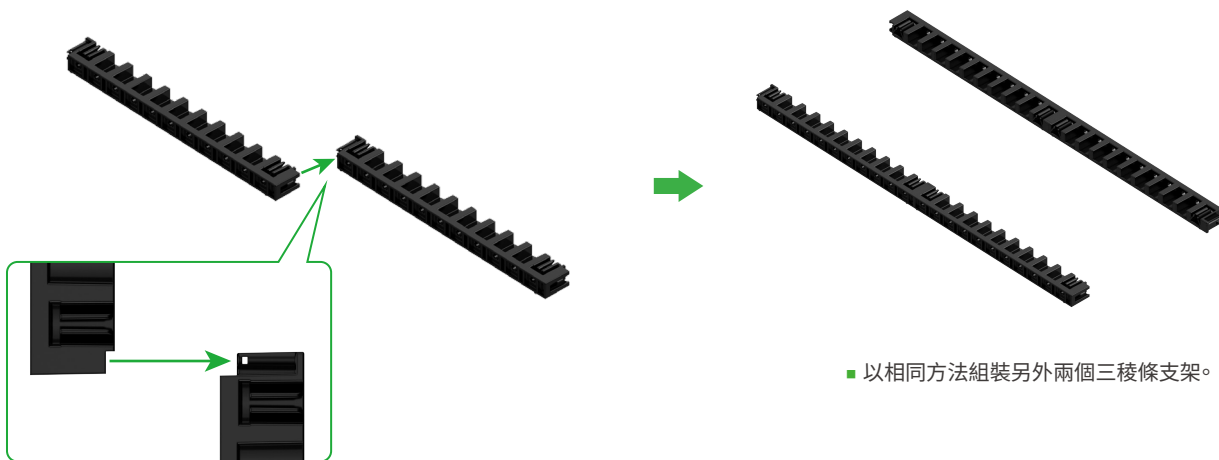
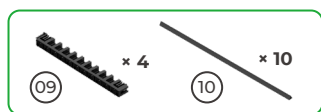

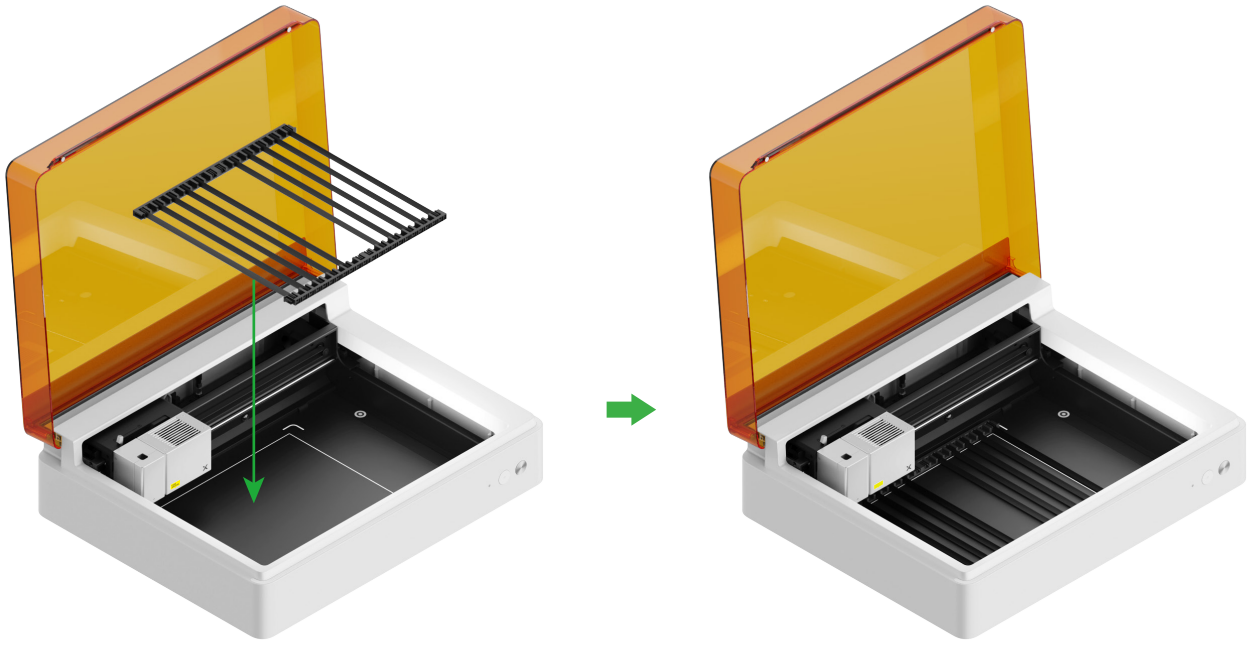

## 使用刀具切割加工或雷射器搭配刀具切割加工時

### (1) 放置切割墊

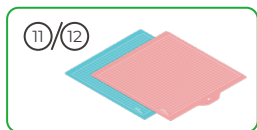

注意：如使用卡紙、牛皮紙等紙質材料，請使用低黏度切割墊；如使用布料等紡織品，則請使用紡織品切割墊。

使用雷射器進行切割加工時，請勿使用切割墊。

切割墊		
顏色	藍色	粉紅色
適用於	輕薄材料	紡織品
材料	卡紙，包裝紙，印刷紙，牛皮紙，珠光紙	紡織品

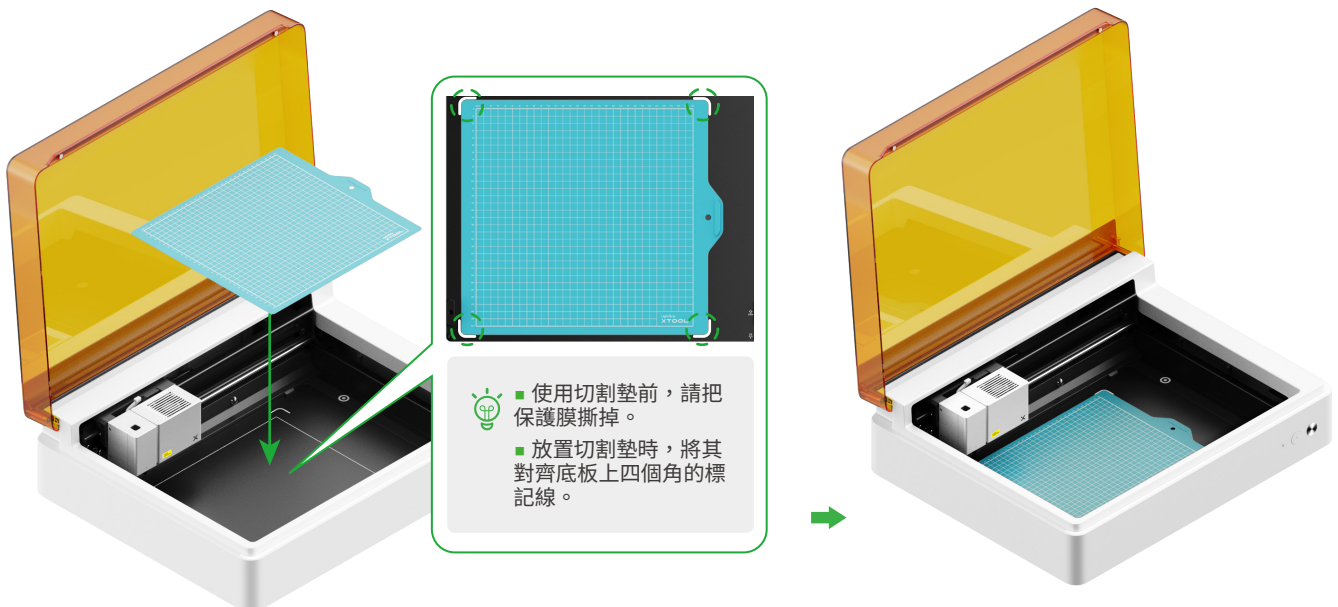



(2) 安裝細切刀

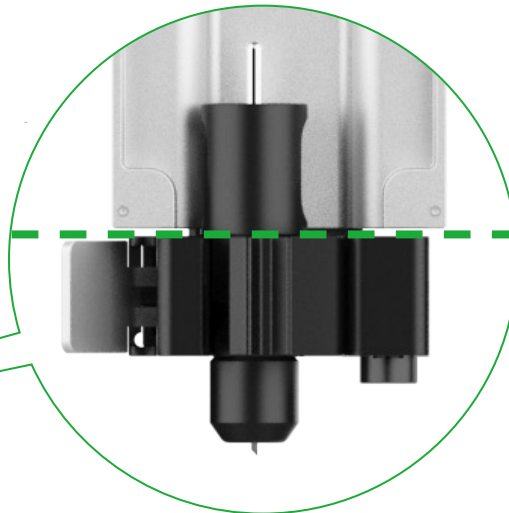
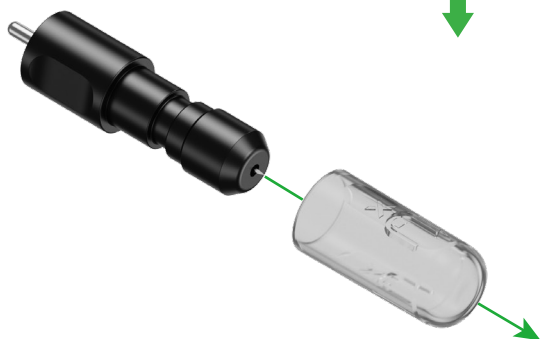
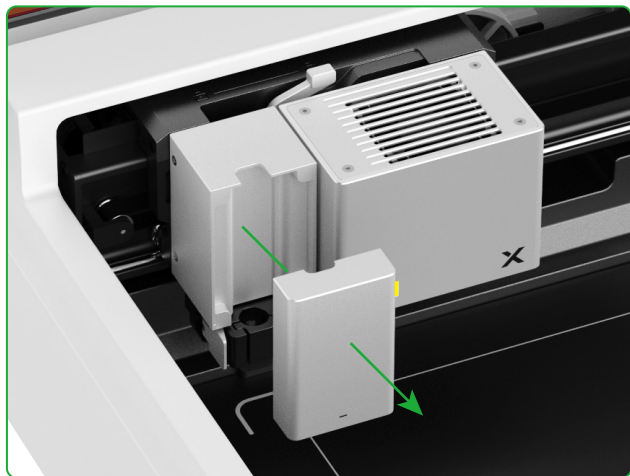

警告！  
刀頭鋒利

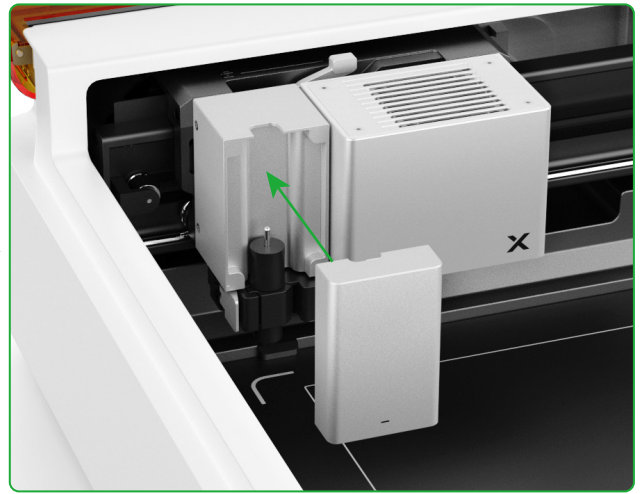
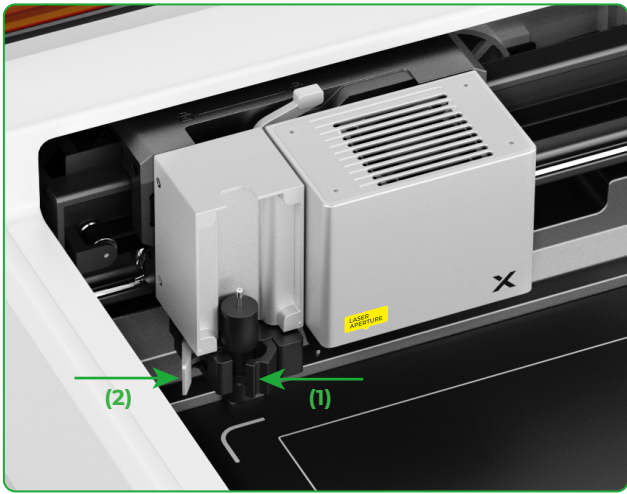

### 使用畫筆加工時

(1) 將針管筆安裝到筆套上

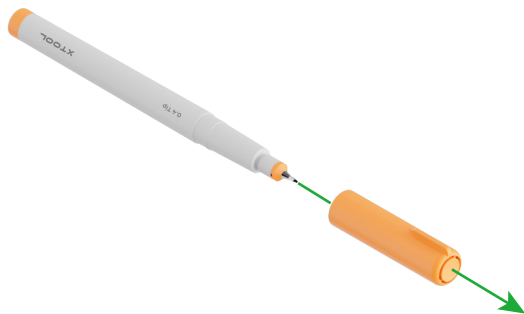

(2) 安裝針管筆

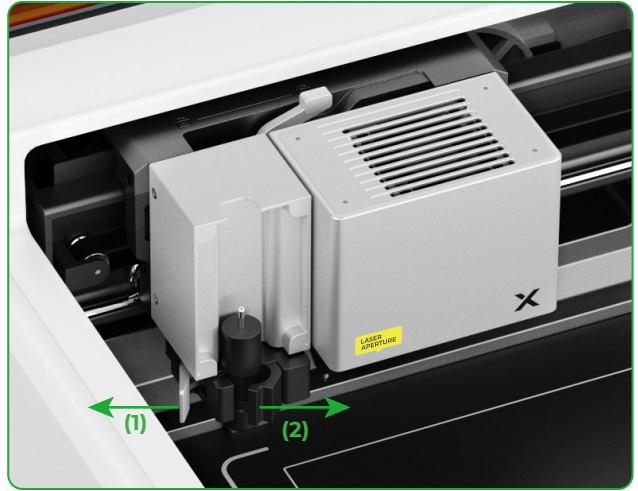
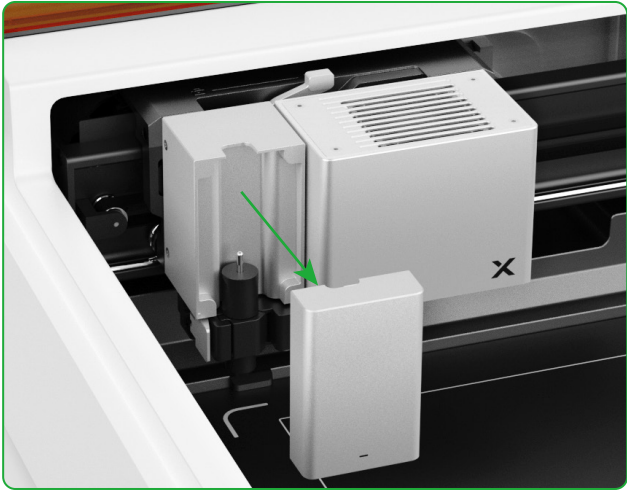

警告！  
刀頭鋒利

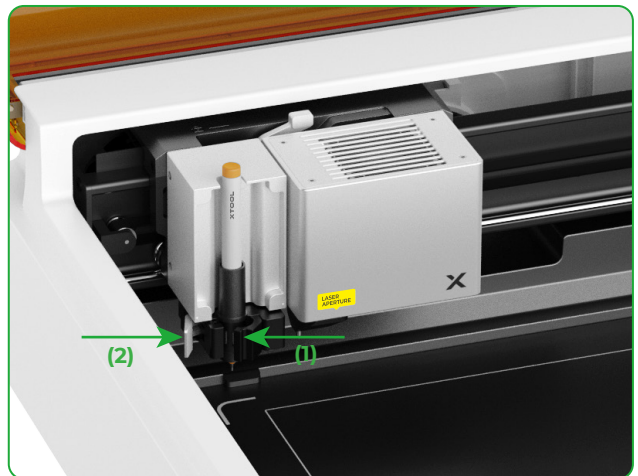
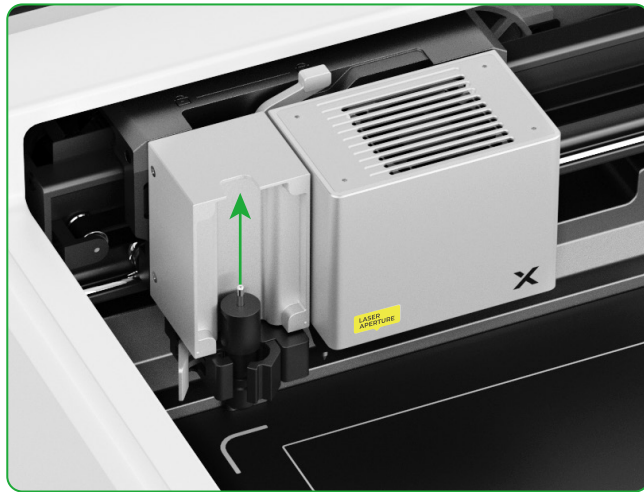



使用其他功能加工時

(1)

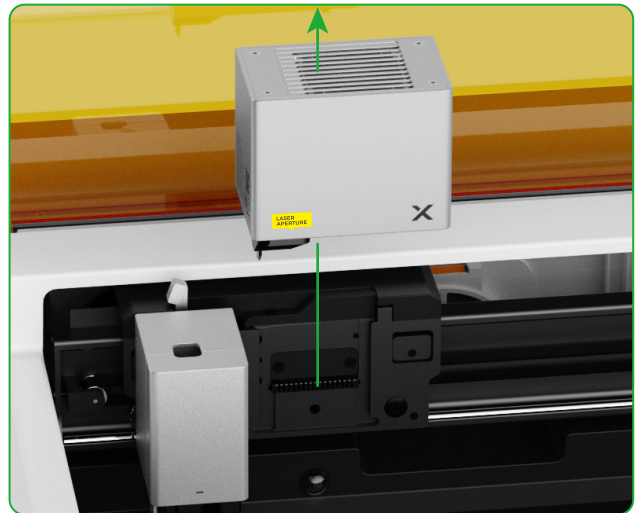
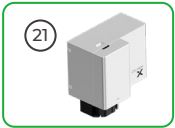

(2) 將相應配件安裝到多功能托架上

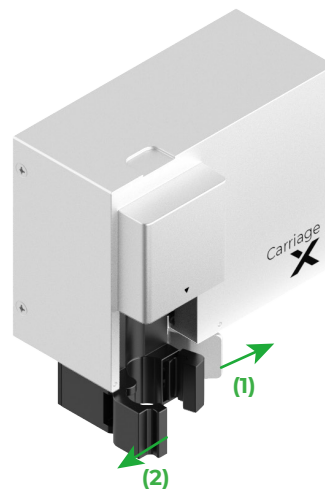
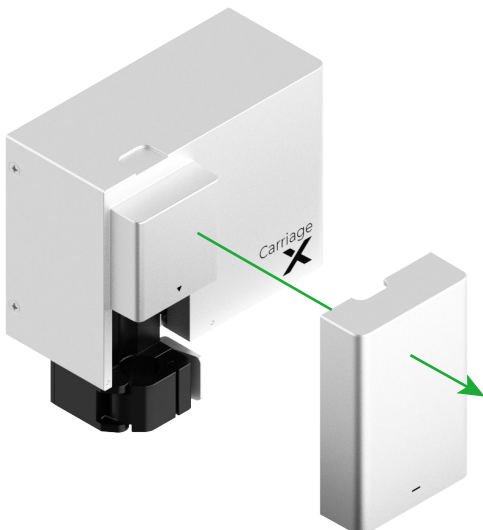





根據加工需求選擇相關的配件。

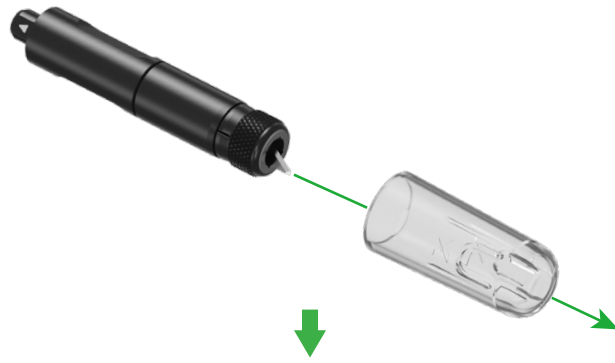

警告！  
刀頭鋒利

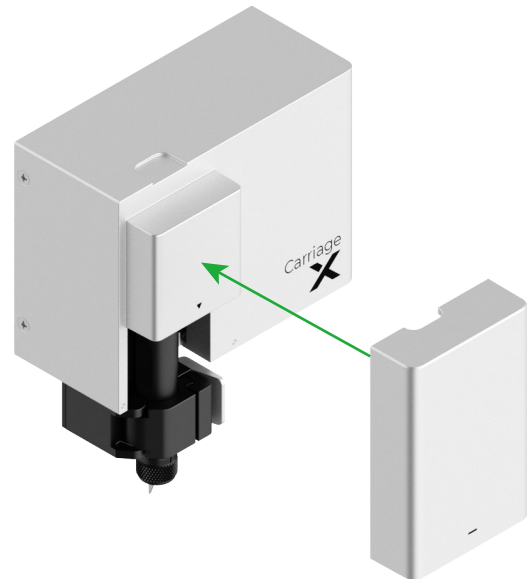
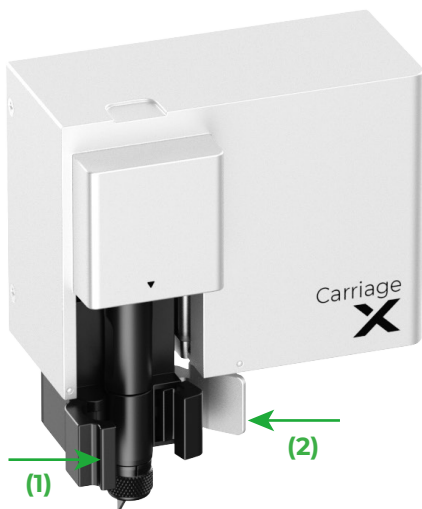
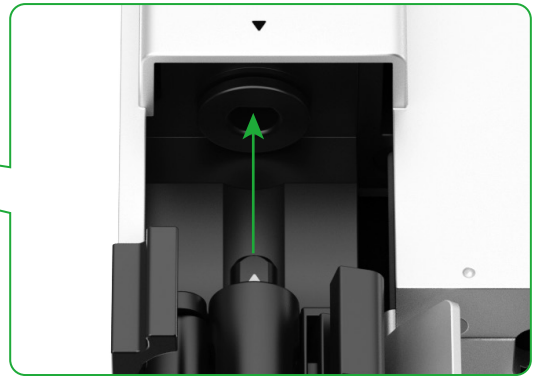

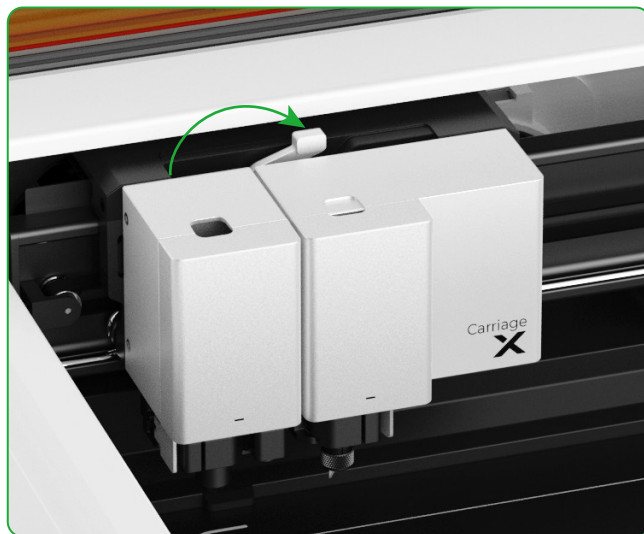
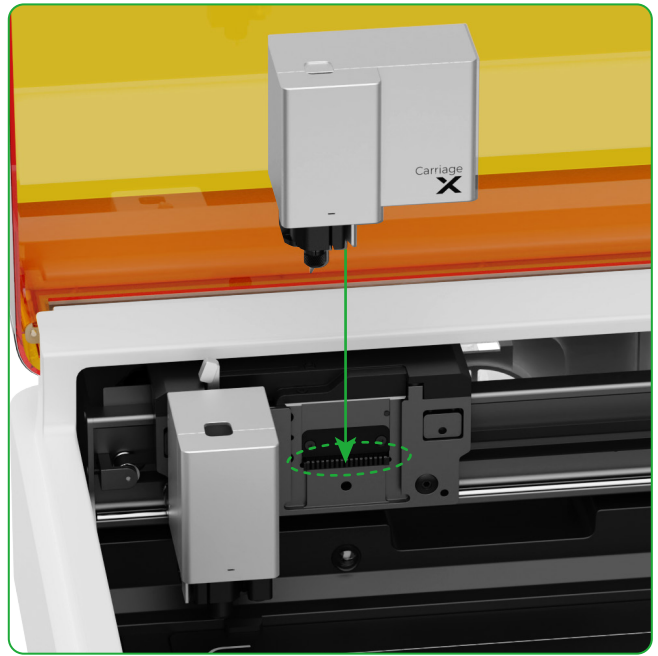

## 指示燈說明

指示燈狀態	蜂鳴器狀態	設備狀態
 白色恆亮	/	未連接軟體,待機 (AP 模式)
 淺藍色恆亮	/	未連接軟體,待機 (STA 模式)
 紫色恆亮	響 1 次	已連接軟體,待機
 白色呼吸	/	已連接軟體,休眠
 紫色呼吸	/	已連接軟體,休眠
 紫色緩慢閃爍	/	韌體更新
 綠色恆亮	/	在軟體上標記加工區域 / 預覽邊框中 / 加工中
 藍色緩慢閃爍	響 1 次	預覽邊框準備就緒 / 加工就緒
 藍色恆亮	/	加工暫停
 黃色閃爍	響 1 次	加工過程中,蓋子被打開或未完全關閉
 黃色閃爍	持續發出聲響	偵測到火焰 (火焰較小) / 設備震動
 紅色閃爍	持續發出聲響	偵測到火焰 (火焰稍大)
 黃色閃爍	響 3 次	設備出現異常
 紅色閃爍	響 3 次	設備出現重大異常



**X**TOOL